

**QUICK SHIP 12 DAYS WITH TOP MOUNTED SELF-CONTAINED REFRIGERATION**

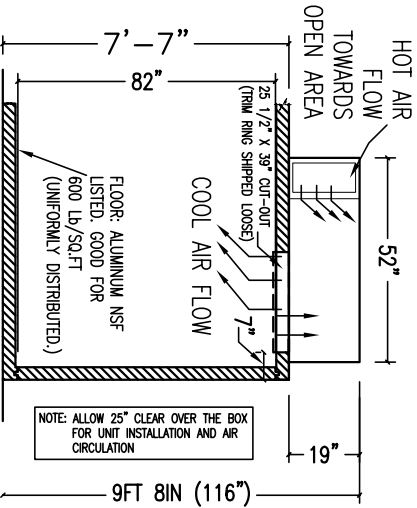
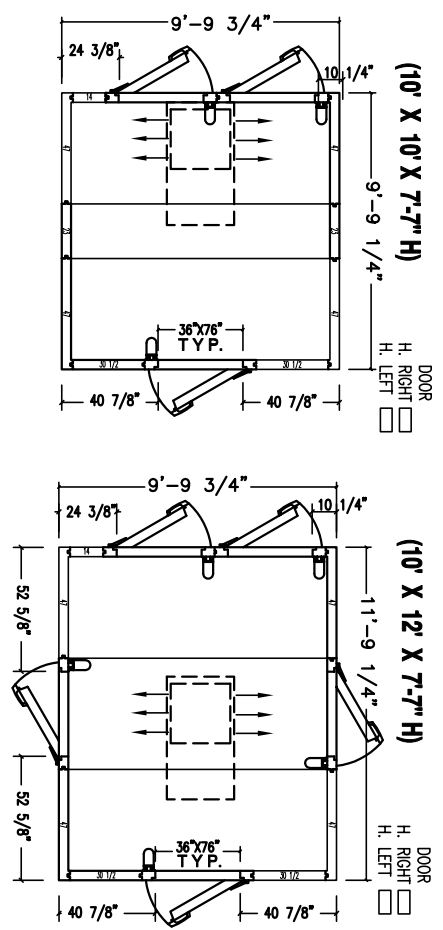
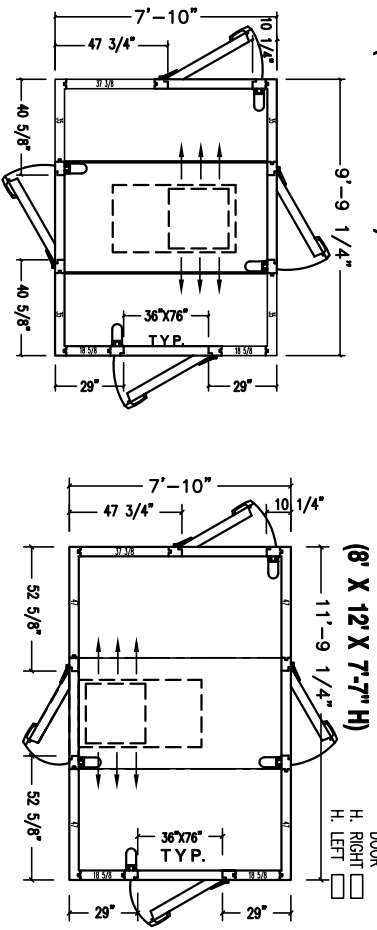
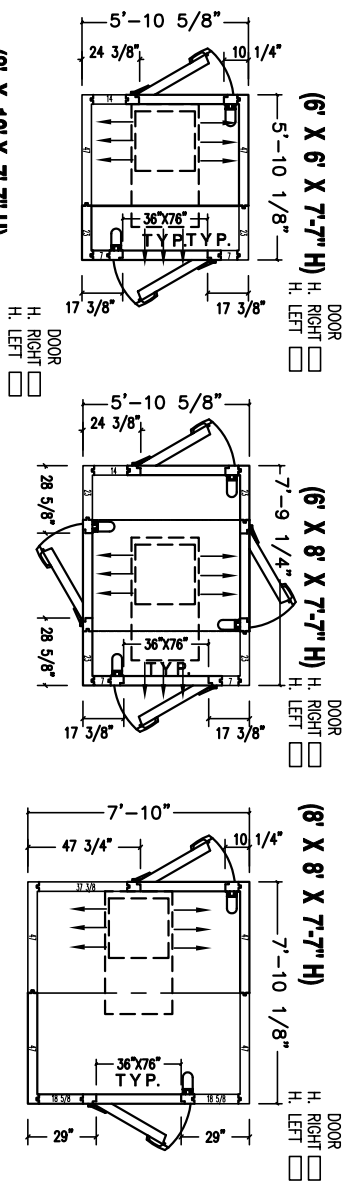

**4" INSULATION:**  
**AK-XPS4™**  
**HI-PERFORMANCE**  
**PANEL CORE**  
**COOLERS R-29**  
**FREEZERS R-32**

**PLEASE SPECIFY IF:**

COOLER SIZE: \_\_\_\_\_  
 WITH FLOOR: \_\_\_\_\_ (OR) WITHOUT FLOOR: \_\_\_\_\_  
 DOOR HINGE: RIGHT: \_\_\_\_\_ (OR) LEFT: \_\_\_\_\_  
 FREEZER SIZE: \_\_\_\_\_  
 WITH FLOOR: \_\_\_\_\_ (OR) WITHOUT FLOOR: \_\_\_\_\_  
 DOOR HINGE: RIGHT: \_\_\_\_\_ (OR) LEFT: \_\_\_\_\_  
 COMMENTS: \_\_\_\_\_

- TOP-MOUNT READY REFRIG. SYSTEM**
- 1-DO NOT USE EXTENSION CORD TO CONNECT UNIT TO POWER SUPPLY
  - 2-ALL CONTROLS ARE PRE-SET
  - 3-FOR INDOOR USE: AMBIENT TEMP. OF 75°F. OUTDOOR USE: AMBIENT TEMP. OF 75°F.
  - 4-UNIT MUST NOT BE ENCLOSED IN AN UNVENTILATED SPACE; NEED VENTILATION
  - 5-NEVER LOCATE THE EVAPORATOR OVER THE DOOR
  - 6-FLUSH BLOWER WITH CEILING PANEL
  - 7-REFRIGERATION SIZES IS FOR HOLDING APPLICATIONS. NO OTHER LOAD HAVE BEEN CALCULATED.



**QUICK SHIP BOXES**

SCALE: NTS	DRAWN BY:	DATE:	REV:
575 EAST 10TH AVE. AMERIKOOLER, INC. 3300 TEL: (908) 994-4334 FAX: (908) 994-2885 FAX: (908) 994-4330			
PAGE: 3 of 43			