

When choosing your walk-in floor consider traffic volume, durability, ease of cleaning, as well as application requirements to deliver lasting floor performance. This AmeriKooler floor selection guide will help you choose a floor that best fits your needs.

Floor Application Guide

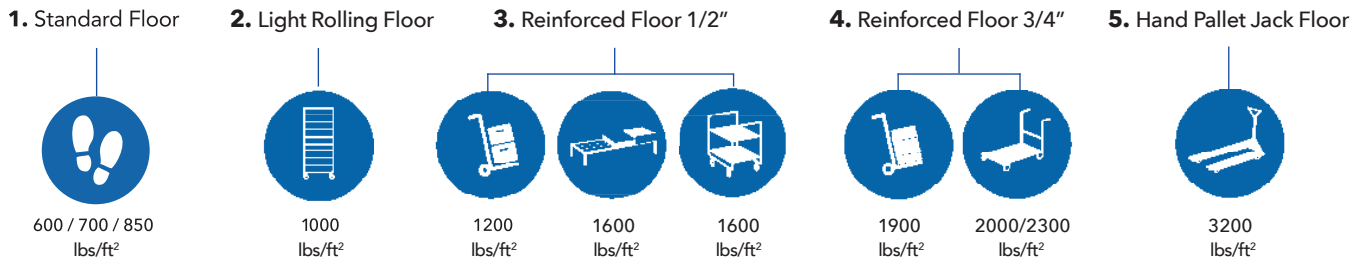

Floor Finishes



.050 SMOOTH ALUMINUM

Floor finish with a 1/2"-radius NSF cove along the interior walk-in perimeter. This floor is rated to support **600 lbs/ft²** of uniformly distributed load. **Foot traffic applications.**

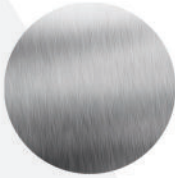

22 GAUGE SMOOTH STAINLESS STEEL

Floor finish with 1/2"-radius NSF cove along the interior walk-in perimeter. This floor offers greater resistance to wear and improves load bearing strength and is rated to support **700 lbs/ft²** of uniformly distributed load. Stainless steel is a sanitary metal finish that is easier to clean and maintain.



20 GAUGE RIGIDIZED STAINLESS STEEL

A stronger alternative to a smooth stainless steel floor finish with 1/2"-radius NSF cove along the interior walk-in perimeter. The rigidized stainless steel finish offers greater resistance to scratches and conceals daily wear and tear. Due to low textured profile, carts are easier to push on this floor finish. It also provides greater foot traffic traction and is easy to clean. Rated to support **1000 lbs/ft²** of uniformly distributed load.



.090 ALUMINUM DIAMOND TREAD PLATE - OVERLAY SHEETS

We recommend aluminum diamond tread plate floor overlay for heavy duty applications. This floor significantly increases resistance to wear. We ship pre-cut overlay sheets that are field installed on an existing floor, overlapping floor panel joints. Overlay sheets increase load bearing capacity by **500 lbs/ft²** of uniformly distributed load.

1. Standard Floor

Suitable for everyday foot traffic applications and a great choice for small compartment walk-ins. Our standard 22 gauge smooth stainless steel floor finish is rated at 700 lbs/ft² of uniformly distributed load.

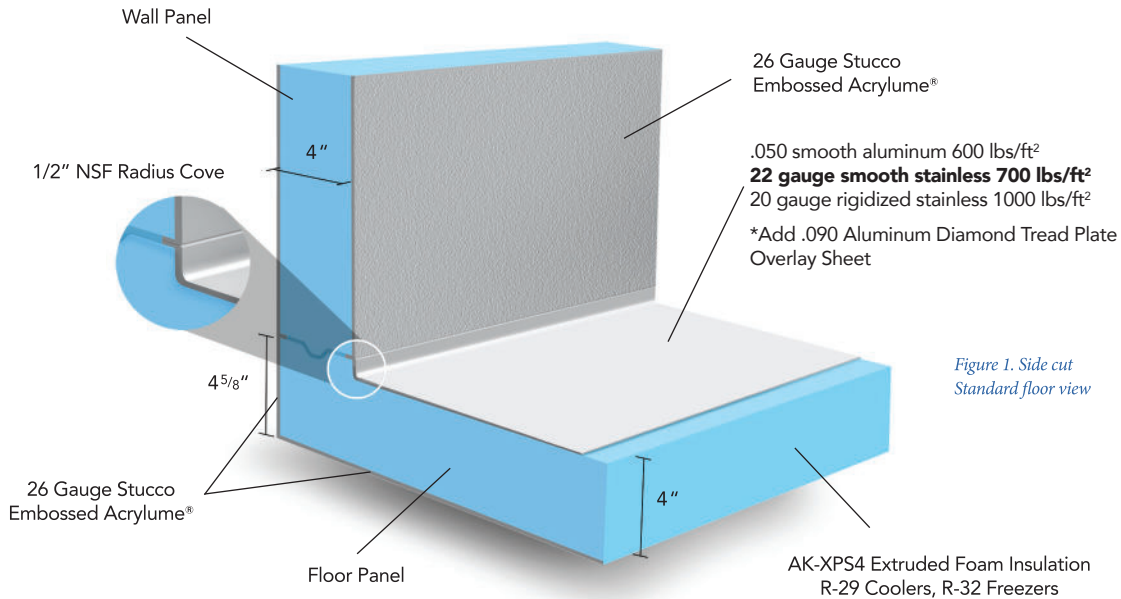

Figure 1. Side cut Standard floor view



FOOT TRAFFIC

2. Light Rolling Floor

Suitable for Pan Rolling Racks with rigidized stainless steel rated at 1000 lbs/ft² of uniformly distributed load.

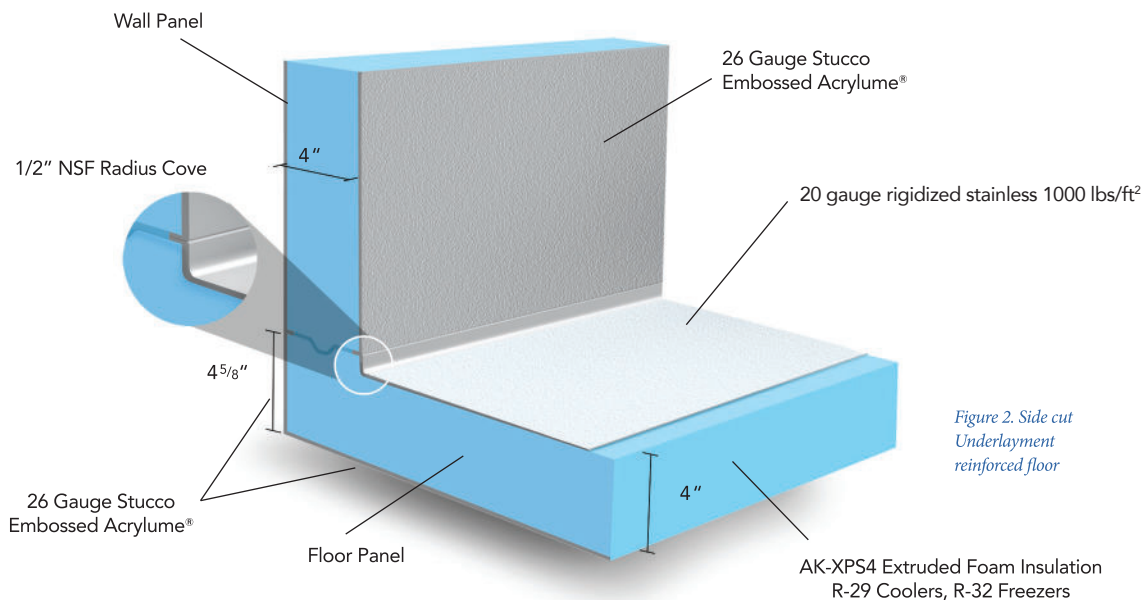

Figure 2. Side cut Underlayment reinforced floor



PAN ROLLING RACKS

3. Reinforced Floor - 1/2" underlayment

Suitable for Pan Rolling Racks, Hand Trucks, Dunnage Racks and Log Carts. With smooth aluminum finish rated at 1200 lbs/ft²; 1300 lbs/ft² with smooth stainless steel; or 1600 lbs/ft² of uniformly distributed load with rigidized stainless steel.

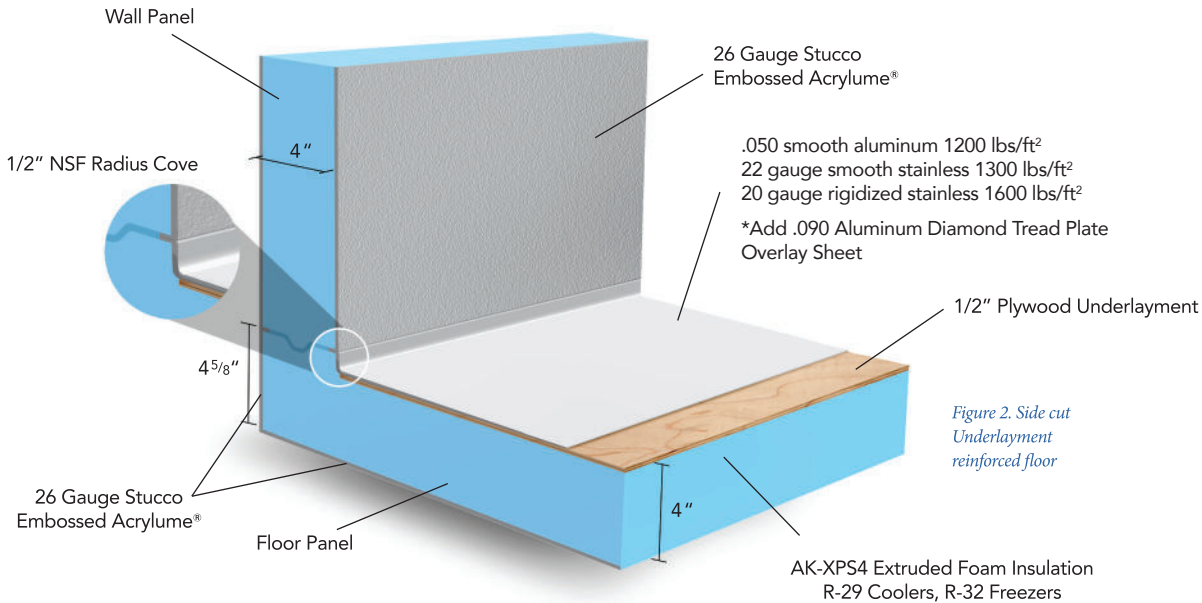

Figure 2. Side cut Underlayment reinforced floor



PAN ROLLING RACKS



HAND TRUCKS



DUNNAGE RACKS



LOG CARTS

4. Reinforced Floor with Overlay - 3/4" underlayment

This reinforced floor offers more even spread of weight across entire floor. This floor is suitable for Hand Trucks, Dunnage Racks, Beer Keg Carts, Log Carts and Dollie Carts. Rated at 1900 lbs/ft² with smooth aluminum finish; 2000 lbs/ft² with smooth stainless steel, and 2300 lbs/ft² of evenly distributed load with rigidized stainless steel.

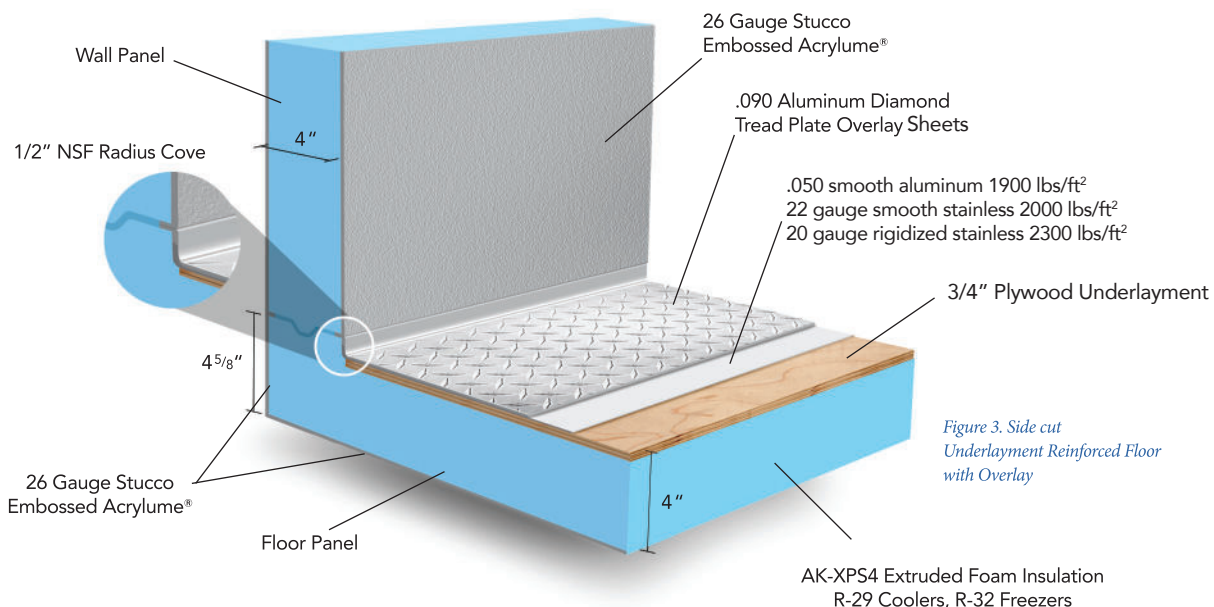

Figure 3. Side cut Underlayment Reinforced Floor with Overlay



HAND TRUCKS



DUNNAGE RACKS



LOG CARTS



BEER KEG CARTS



DOLLIE CARTS

5. Hand Pallet Jack Floor

AmeriKooler Hand Pallet Jack floor is rated at 3200 lbs/ft² of evenly distributed load with rigidized stainless steel finish.

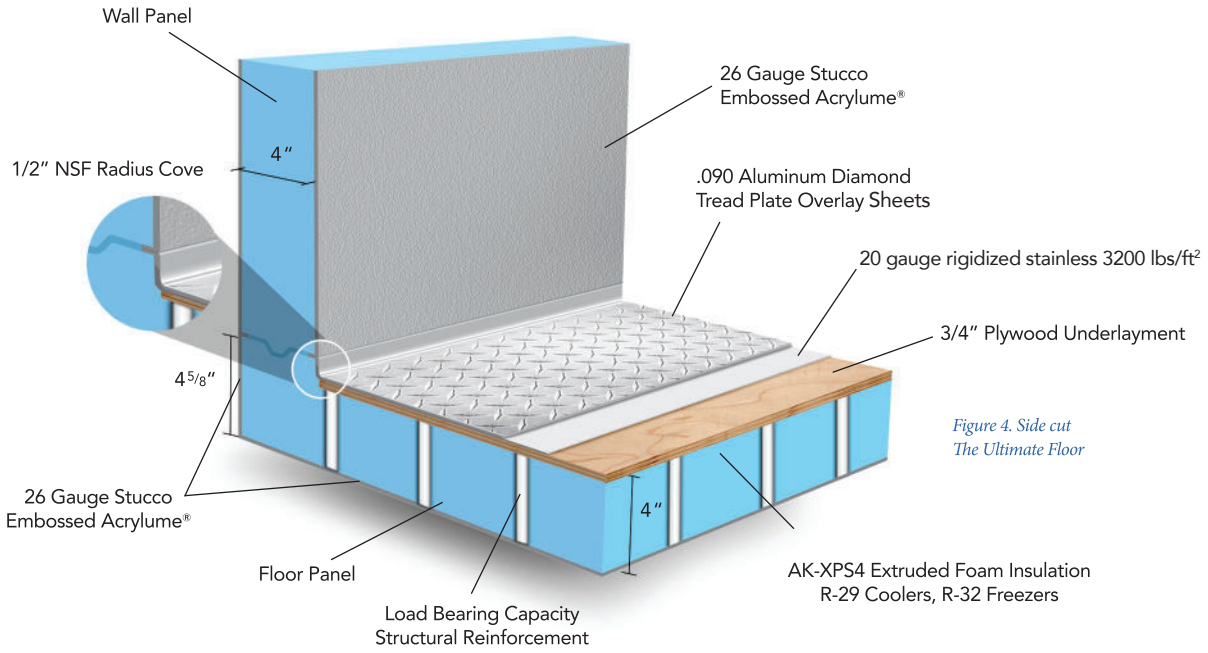

Figure 4. Side cut
The Ultimate Floor



BEER KEG CARTS



DOLLIE CARTS



HAND PALLET JACK

Maintenance Guidelines

We recommend cleaning walk-in floors with a damp mop. Use of excess or pooling water will void warranty.

Popular Ramp Options

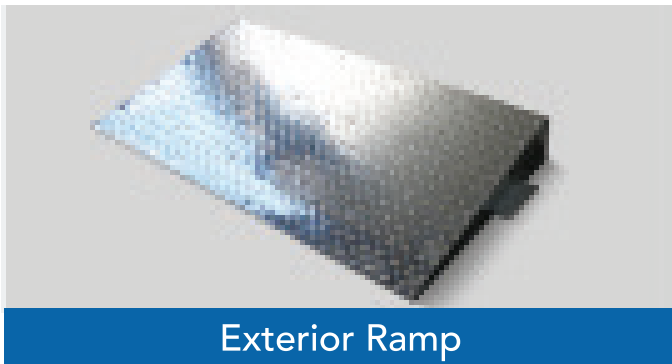

Exterior Ramp



Interior Ramp

Standard sizes: 24" deep for 26", 30" and 36" wide door opening.



NSF International



Underwriters
Laboratory



Miami-Dade
County Approved



State of Florida
Approved



LARR LA
Research



City of New York-MEA



State of Oregon



EISA Compliant



City of Houston



Hydrophobic
Insulation ASTM C272

Specifications are subject to change without notice due to our continuous product improvements.